

## 1 DESCRIPTION

The patented and forged chain connectors are intended exclusively for joining round link, flat type and special chains of conveying systems, mainly in the mining industry. The chain connectors will run only on vertically arranged sprockets.



Each chain connector consists of two symmetrical halves which are locked in place with dowel pins.

Depending on the type of connector, the two connector halves are secured against accidental opening, either by a central pair of pins (Figures 1 and 4; name extension "CP" = central pin) or by two pairs of pins, one placed at each end.



Figure 1: Standard version and Central Pin version (CP)

The two paired connector halves are manufactured to match each other and must be used only together.

For ease of identification, the two connector halves of a pair are marked with identical numbers, as shown in Figure 2.

The dowel pins are intended for single use only.



Figure 2

## 2 TECHNICAL DATA

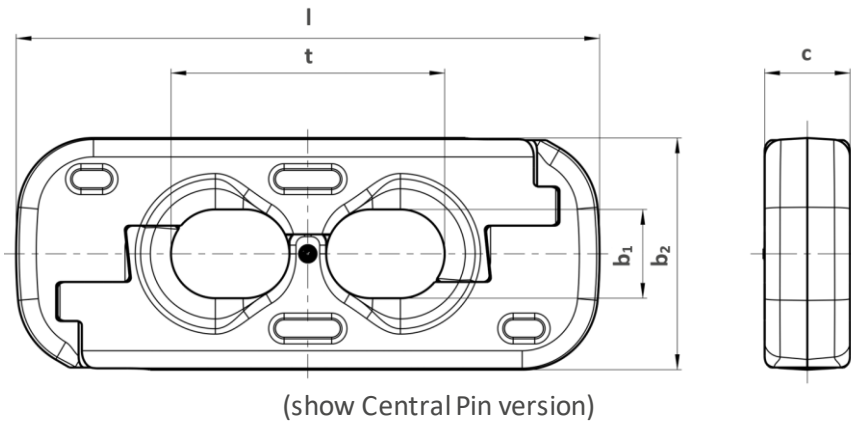

Nominal chain size d x t	Type	Article no.	t	b <sub>1</sub> min	b <sub>2</sub> max	l max	c max	Breaking force min [kN]	Mass [kg]	Large dowel pin	Small dowel pin
			[mm]	[mm]	[mm]	[mm]	[mm]			Article no.	Article no.
for ROUND LINK- and FLAT CHAINS											
34 x 126		F26320	126	37	98	283	36	1 600	5,7	Z07863	Z07862
38 x 126	CP	F26333	126	41	110	273	40	1 820	6,8	Z00083	Z00448
38 x 137		F26335	137	41	110	312	40	2 000	8,1	Z07053	Z07451
38 x 146		F26330	146	41	110	336	40	2 000	8,9	Z07053	Z07451
42 x 146		F26341	146	44	115	334	43,5	2 500	9,8	Z07206	Z06562
48 x 144/160		F26350	144	50	123	356	59	3 100	14,7	Z00303	Z00302
48 x 152		F263621	152	50	128	337	56	2 900	13,4	Z09490	Z08671
for BROADBAND-CHAINS											
38 x 126/148	CP	F26338	126	40	86	315	54	2 050	8,4	Z00299	Z03608
42 x 128/164	CP	F26348	128	44	99	343	60	2 500	12,0	Z00311	Z03892
50 x 146/174	CP	F26365	146	52	116,8	367	64,1	3 390	16,0	Z00311	Z03892
56 x 168/204	CP	F26377	168	61	130	403	75	4 000	21,5	Z10177	Z10176
for SUPERFLAT CHAINS											
38 x 126	CP	F263331	126	41	101	273	40	1 820	6,4	Z00448	Z00083
38 x 146		F26330	146	41	110	336	40	2 000	8,9	Z07053	Z07451
42 x 146	CP	F26344	146	44	108	318	44	2 500	8,4	Z00890	Z00083
48 x 144/160		F26349	144	50	115	333	59	2 900	12,6	Z00303	Z00916
48 x 152		F26357	152	50	116	339	56	2 900	12,4	Z08671	Z09490
52 x 170		F26369	170	55	125	365	62	3 400	14,7	Z00303	Z00916
56 x 187	CP	F26378	187	61	132	413	65	3 940	19,2	Z00342	Z00420
60 x 181	ULTRA	F26385	181	62	136	417	66	4 520	21,8	Z08671	Z09490
for POWER CHAINS											
34 x 110		F26326	110	36	87	253	49	1 450	6,3	Z00351	Z09008
42 x 140		F263461	140	44	108	325	62	2 500	12,0	Z00342	Z00420

- CP = Central Pin version
- The number of dowel pins depends on the type

### 3 ASSEMBLY

1. Open the chain connector by pulling the two connector halves apart in longitudinal direction and lifting up one half.
2. Check the chain connector for completeness and identical markings.
3. Shut down the conveyor and secure it against accidental operation.



Figures 3 and 4

4. Place one connector half in the conveyor. Following that, place the two horizontal chain ends of the chain strands to be joined in that connector half (Figures 3 and 4).



Figure 5

5. Now place the second connector half in position as shown in Figure 5 and push the two connector halves together, making sure that the two boreholes for the pins are aligned. When working on several chain strands, take special care to make sure that the connector halves have identical markings.



Figure 6

6. First drive the large dowel pin/s into the borehole/s. Then drive the smaller dowel pin/s into the larger pin/s (Figure 6). Make sure that the pin slots are staggered by at least 90 degrees and do not project from the contour of the chain connector halves. The dowel pins are for single use only.
7. Remove tools and other foreign objects from the conveyor before restarting it.



## 4 DISASSEMBLY

1. Shut down the conveyor and secure it against accidental operation.
2. Detension the chain/s.
3. Remove the dowel pins using a punch.
4. Tap connector halves apart with a hammer (Figure 7). Make sure that your fingers are not in the opening zone. There is a risk of crushing if the lock halves slide apart!



Figure 7

## 5 WEAR

In case of significant damage, the chain connectors must be replaced.

From an elongation of the pitch  $t$  by more than 3 %, the chain connectors must be replaced.

## 6 ENVIRONMENT

Ensure appropriate and environmentally friendly use of lubricants.

Dispose of worn out steel components and accessories for scrapping according to local regulations. Dispose of packaging in accordance with local regulations.

## 7 THIELE MOUNTING AND OPERATING INSTRUCTIONS

Current mounting and operating instructions are available as a PDF download on the THIELE homepage.



## 8 IMPRINT

THIELE GmbH & Co. KG

Werkstrasse 3

58640 Iserlohn

Germany

Tel.: +49 (0) 2371 / 947 - 0